

COM-ICDB7

COM Express Type 7 with Intel® 3rd Gen XEON D Processor

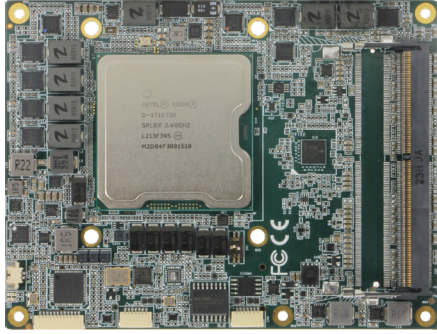

Features

- Intel® Idaville Platform Ice Lake-D (XEON-D) LCC series, max TDP 67W
- 2x SODIMM DDR4 Sockets, up to 64GB (ECC Support)
- Intel i210IT Gigabit Ethernet x 1
- 10GbE x 4 (via x557-AT4 on carrier board)
- SATA3.0 x 2
- USB3.2/2.0 x 4
- PCIe[x16], PCIe [x4] x 4
- 12V DC input
- COM Express Type 7, Basic size, 125mm x 95mm



Specifications

System	
Form Factor	PICMG COM Express R3.0, Type 7
CPU	Intel® Idaville Platform XEON-D1700 LCC Processor
CPU Frequency	Up to D-1746TER (2.0 GHz)
Chipset	SoC
Memory Type	DDR4 SODIMM Socket x2
Max. Memory Capacity	Up to 64 GB (ECC Support by sku)
BIOS	AMI BIOS (UEFI)
Wake on LAN	Yes
Watchdog Timer	255 Levels
Power Requirement	+12 V and +5 VSB for ATX, +12V for AT
Power Supply Type	AT (default) / ATX
Power Consumption (Typical)	7.75A @12V, D-1746TER
Dimension (L x W)	4.92" x 3.75" (125mm x 95mm)
Operating Temperature	32°F ~ 140°F (0°C ~ 60°C),
Storage Temperature	-40°F ~ 185°F (-40°C ~ 85°C)
Operating Humidity	0% ~ 90% relative humidity, non-condensing
Certification	CE / FCC Class A (Pre-test with Class B standard)
Display	
Graphic Controller	—
Video Output	—
I/O	
Ethernet	1GbE: Intel® i210IT GbE 10GbE: 4x10G Base-KR to carrier
Audio	—
USB Port	USB2.0 x 4, USB3.2 Gen1
Serial Port	2-Wire UART(Tx/Rx) x2
HDD Interface	SATA 3 x 2
Expansion Slot	PCIe [x16] x1, 4x PCIe [x4] I2C (Windows 10 Ready.) LPC SMBus
GPIO	8-bit
Onboard Storage	—
TPM	TPM 2.0

Packing List

- COM-ICDB7 x 1

Optional Accessories

- **ECB-927A-A10-0001**
COMe T7 Carrier Board. 4x10G via x557. 4USB3.PEG+PCIe.2COM.2SATA.AT/ATX.Rev A1.0
- **COM-ICDB7-FAN01**
CPU Cooler.FAN+HeatSink.125*95*50mm.12V.for COM-ICDB7
- **COM-ICDB7-HSP01**
Heat Spreader.125*95*11mm.Black.COM-ICDB7

CPU Support Chart

CPU	Core / Thread	Base Frequency	Max Turbo Frequency	Graphic
D-1746TER	10c/10t	2.0	3.1	—
D-1735TR	8c/8t	2.2	3.4	—
D-1732TE	8c/8t	1.9	3.0	—
D-1715TER	4c/4t	2.4	3.5	—
D-1712TR	4c/4t	2.0	3.1	—

Block Diagram Unit: mm

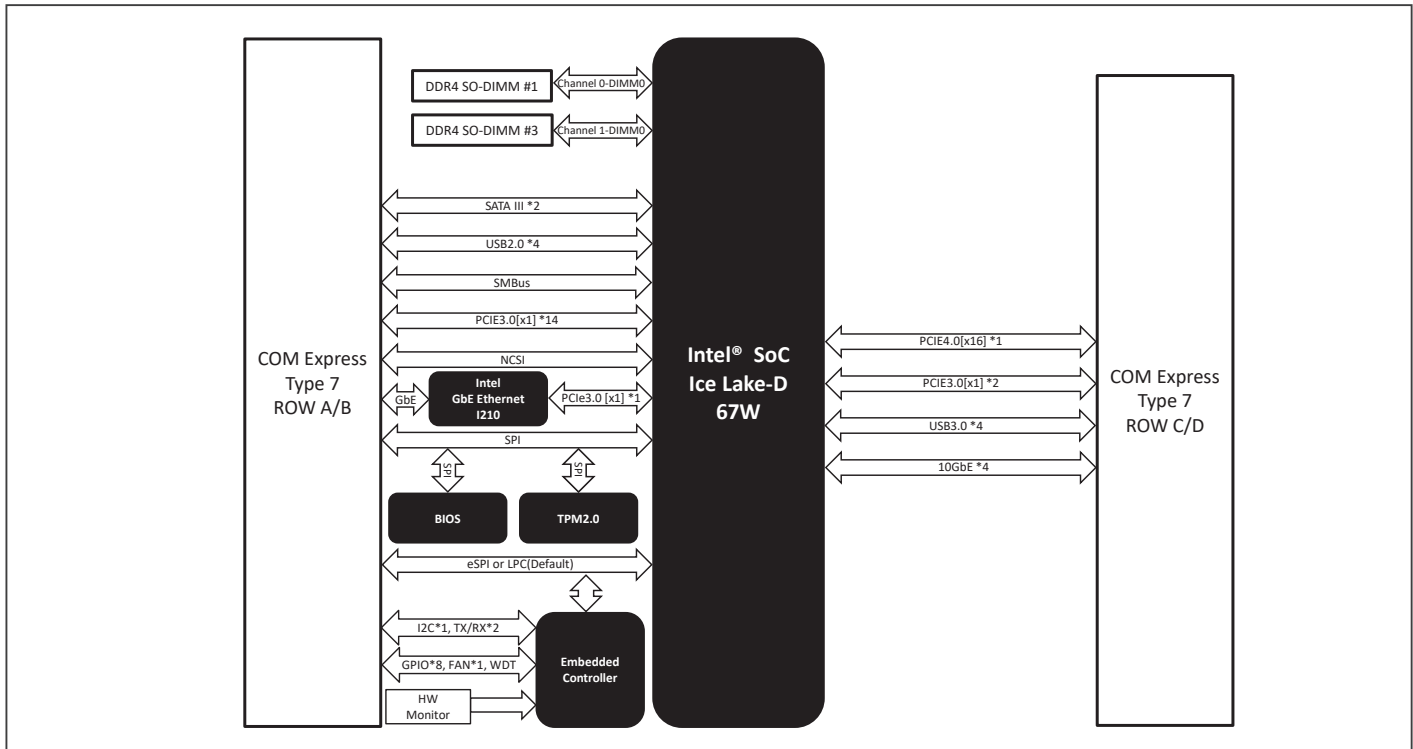

Dimension Unit: mm

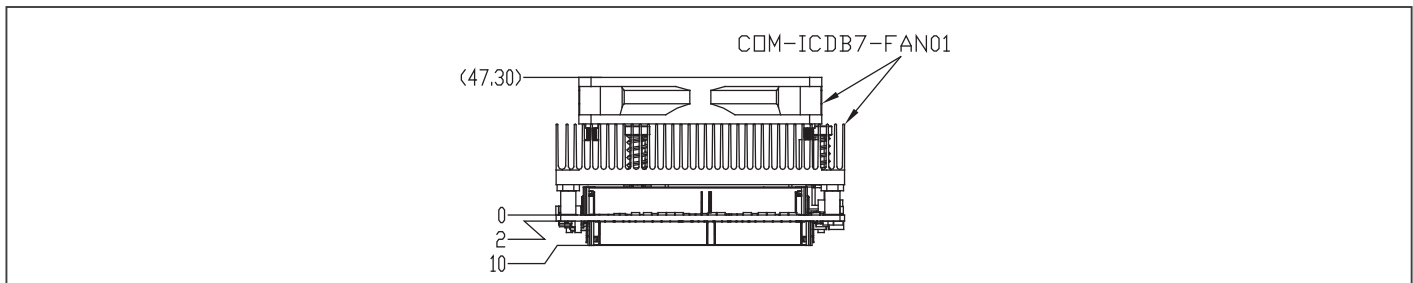

Ordering Information

Part Number	COM Express Type	CPU	Memory	Display	LVDS	Storage	LAN	USB	UART	Expansion	Power	Temperature	Other
COM-ICDB7-A10-0001	COM Express R3.0, Type 7	D-1746TER,10c	DDR4 SODIMM x 2	—	—	SATA 3 x 2	1GbE: Intel® I210IT GbE 10GbE: 4x 10G Base-KR	USB2.0 x 4, USB3.2 Gen1	2-Wire UART(Tx/Rx) x2	PCIe [x16] x1, 4x PCIe [x4]	+12V	0°C ~ 60°C	LPC, SMBus, I2C, GPIO 8bit
COM-ICDB7-A10-0002	COM Express R3.0, Type 7	D-1735TR,8c	DDR4 SODIMM x 2	—	—	SATA 3 x 2	1GbE: Intel® I210IT GbE 10GbE: 4x 10G Base-KR	USB2.0 x 4, USB3.2 Gen1	2-Wire UART(Tx/Rx) x2	PCIe [x16] x1, 4x PCIe [x4]	+12V	0°C ~ 60°C	LPC, SMBus, I2C, GPIO 8bit
COM-ICDB7-A10-0003	COM Express R3.0, Type 7	D-1732TE,8c	DDR4 SODIMM x 2	—	—	SATA 3 x 2	1GbE: Intel® I210IT GbE 10GbE: 4x 10G Base-KR	USB2.0 x 4, USB3.2 Gen1	2-Wire UART(Tx/Rx) x2	PCIe [x16] x1, 4x PCIe [x4]	+12V	0°C ~ 60°C	LPC, SMBus, I2C, GPIO 8bit
COM-ICDB7-A10-0004	COM Express R3.0, Type 7	D-1715TER,4c	DDR4 SODIMM x 2	—	—	SATA 3 x 2	1GbE: Intel® I210IT GbE 10GbE: 4x 10G Base-KR	USB2.0 x 4, USB3.2 Gen1	2-Wire UART(Tx/Rx) x2	PCIe [x16] x1, 4x PCIe [x4]	+12V	0°C ~ 60°C	LPC, SMBus, I2C, GPIO 8bit
COM-ICDB7-A10-0005	COM Express R3.0, Type 7	D-1712TR,4c	DDR4 SODIMM x 2	—	—	SATA 3 x 2	1GbE: Intel® I210IT GbE 10GbE: 4x 10G Base-KR	USB2.0 x 4, USB3.2 Gen1	2-Wire UART(Tx/Rx) x2	PCIe [x16] x1, 4x PCIe [x4]	+12V	0°C ~ 60°C	LPC, SMBus, I2C, GPIO 8bit