

# AI Inference/ MegaEdge

# MXM Series AIP-SQ67A-A1/ AIP-SQ67B-A1



## Features

- Supports Intel® 12th Gen Core™ i7/i5 processors, TDP under 65W
- Intel® Q670E Chipset
- 5x DP++(Supports MST);1 from Integrated Graphic, 4 from MXM
- 2x M.2 M-Key NVME Gen 4x4 /SATA
- 5x 2.5G RJ45 LAN Ports
- 6x USB 3.2 Gen2 x1 Type-A
- 1x USB 3.2 Gen2 x2 Type-C
- Built-in out-of-band remote management module

## Specifications

Model Number	AIP-SQ67A-A1	AIP-SQ67B-A1
CPU	Intel® Core™ i5-12500E Processor	Intel® Core™ i7-12700E Processor
Chipset	Intel® Q670E Chipset	
GPU Card(Optional)	MXM Type A · Type B · Type B+	
System Memory	2 x 260-pin Socket Support DDR5 SO-DIMM, Up To 32 GB Per DIMM	
Storage	2x 2.5" SATAIII SSD/HDD 2x M.2 M Key Slot, Support PCIe x4 for NVME, Size 2280/SATA	
Front I/O	3x USB3.2 Gen2 Dual Connector 1 x USB 3.2 Gen2 x2 (20G) USB Type C Connector 5 x RJ45 LAN Connector(1+4),2.5G bps 4 x RS-232/RS-422/RS-485 (COM1~4)	
Rear I/O	4 x Display Port (DP++, From MXM Port A/B/C/D) 1 x Display Port(DP++, From CPU) 2 x Audio Jacks, Support Line Out/Mic 2x CAN Bus-Isolation 2.0B 2x USB2.0 Gen2 Connector	
Expansion	1 x MXM Slot (Type B plus) 1 x M.2 M Key Slot, Support PCIe Gen4x4+ SATA Interface for NVME, Size 2280 1 x M.2 M Key Slot, Support PCIe Gen4x4+ SATA Interface for NVME, Size 2280 (Support InnoAGE)	
MISC. Function	OOB (out of band), Built-in Innodisk - InnoAgent	
Power Consumption	Idle: 170 Watts(w/o MXM) Full loading: 170 Watts(w/o MXM)	
Power Input /Connector	DC-in 24V / 4-pin Terminal Block	
Dimension (Wx Dx H)	270.0 x 155.0 x 252.0mm (10.62" x 6.10" x 9.92")	
Mounting	Deskmount	
Net Weight	5.5 kg (12.13 lb)	
Vibration	2 Grms ,IEC60068-2-64,Random,5 ~ 500 Hz ,1Hr / Axis	
Shock	5G, IEC 60068-2-27, Half Sine, 11 ms Duration	
Temperature	Operating Temp.:0°C ~ + 50°C (With Expansion Kit)(32°F ~ 122°F) / Storage Temp.: -40°C ~ + 85°C (- 40°F ~185°F)	
Humidity	95% @ 40°C Related Humidity, Non-condensing	
OS Support	Ubuntu 22.04 · Windows 10	
Certification	CE/FCC Class B · BSMI · LVD	

### System & Mounting Dimensions

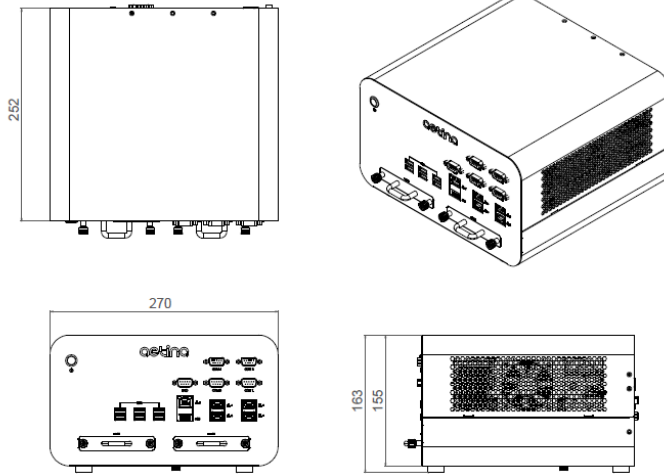

### I/O Mechanical Layout

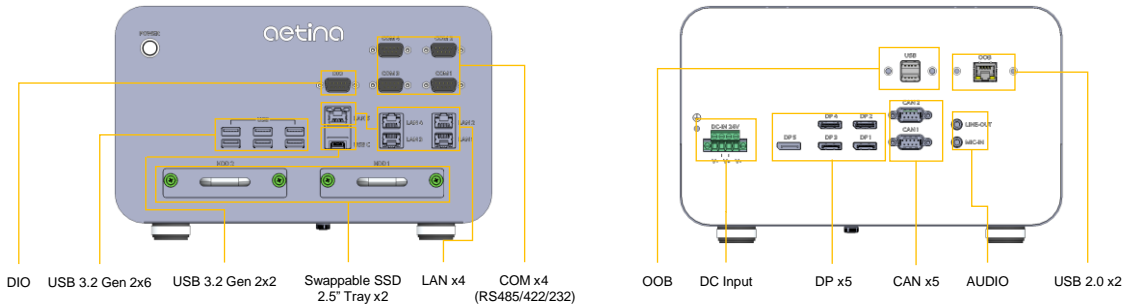

### Ordering Information

Model name	Description
AIP-SQ67A-A1	Support Intel® i5 Processor /SO-DIMM DDR5 4800 /2.5" SSD
AIP-SQ67B-A1	Support Intel® i7 Processor /SO-DIMM DDR5 4800 /2.5" SSD

### Accessory (Optional)

Part No.	Description
32-010000-0005	US Power Cord SVT 18AWG Cable 1800mm Black 105 °C
32-010000-0006	EU Power Cord H05VV-F 0.75mm2/3G SL-6+SL-3 Cable 1800mm Black
53-0F0000-0009	600w Adapter(AC/DC Cable)
53-0C4800-0002	DDR5 SO-DIMM 4800 MT/s 16GB 0~95°C
53-0C3TE7-0008	SATA III 2.5" SATA SSD 1T 3TE7 3D TLC 0~70°C
42-0W10IE-19V0	License Sticker-Win 10 IoT Ent 2019 LTSC-Value
42-0W10IE-19H0	License Sticker-Win 10 IoT Ent 2019 LTSC-High End

